

## Integrated Compressed Air Foam Systems

### FPO OSCILLATING NOZZLE



The FireFlex ICAF Nozzle Model FPO is an oscillating type CAF nozzle specifically designed to be used with the FireFlex ICAF System. It is designed to discharge CAF over a specific hazard.

FPO Nozzles are used on applications where flammable liquid spills (hydrocarbons or polar solvents) can occur on horizontal surfaces and may result in a spill or pool fire. The FPO Nozzle configuration is therefore designed to provide a specific discharge over the protected surfaces or areas from a low level while discharging CAF through an arc of either 90 or 180 degrees.

Located near the hazard and directly aimed at the surface to be protected, the FPO Nozzle can be used for most Class B Fire applications instead of using AFFF foam-water systems.

#### 1. Nozzle materials:

Base: 300 Series Stainless Steel  
 Outlet: 300 Series Stainless Steel  
 Impeller: Electroless Nickel Plated Steel  
 Finish: Complete assembly is spray painted fire red

#### 2. Features:

The FPO Nozzle is extremely effective at extinguishing fires. It uses less foam solution at a lower design density, which greatly reduces the environmental impact and disposal costs associated with AFFF Foams.

The FPO Nozzle delivers a robust foam blanket with an expansion ratio of 10 to 1 and a longer drain time than regular AFFF systems. This produces an extended burn-back protection not found with other foam technologies.

Fires are also extinguished with minimal steam production, thereby greatly increasing visibility at the fire scene for easier egress and firefighting.

The FPO nozzle is self-propelled by the CAF discharge and does not require any electrical or hydraulic connection, considerably simplifying installation.

Inlet connection is either threaded or grooved depending on model size. The CAF discharge outlet is not adjustable, eliminating the possibilities of field tampering which could impede on the designed discharge pattern. The outlet is also provided with a blow-off cap in order to prevent accumulation of foreign matter inside the nozzle.

#### 3. Typical Applications:

- Aircraft hangars
- Helipads
- Fuel gantries
- Loading / unloading racks
- Diked areas

#### 4. Nozzle spacing and location:

The FPO Nozzle spacing shall be based on its discharge pattern. Using the table below, nozzles shall be spaced and aimed so that their discharge pattern will cover the entire hazard surface at a density no less than 0.025 gpm/sq.ft. on hydrocarbons and 0.06 gpm/sq.ft. on polar solvents.

The presence of obstructions and the potential for shielding of spray patterns should be evaluated to ensure that the system performance is not affected.

Nozzle PART NO.	Inlet Dia (in.)	Flow (gpm)	Nozzle Spray Coverage		
			Arc of rotation (Deg)	Min. Range (FT)	Barrel Size (inch)
<b>HYDROCARBONS (at 3% concentration)</b>					
FPO-2-090-H8-U	2 (T)	48	90°	43	1½" Dia x 6" Long
FPO-2-090-H8-D	2 (T)	48	90°	45	1½" Dia x 6" Long
FPO-4-090-H16-U	4	96	90°	58	2½" Dia x 12" Long
FPO-4-180-H16-U	4	96	180°	43	1½" Dia x 10" Long
FPO-4-090-H32-U	4	192	90°	92	2½" Dia x 12" Long
FPO-4-180-H32-U	4	192	180°	63	1½" Dia x 10" Long
<b>POLAR SOLVENTS (at 6% concentration)</b>					
FPO-2-090-P8-U	2 (T)	48	90°	30	1½" Dia x 2¼" Long
FPO-2-090-P8-D	2 (T)	48	90°	30	1½" Dia x 2¼" Long
FPO-4-090-P16-U	4	96	90°	45	2½" Dia x 2¼" Long
T: Indicates threaded inlet connection. All other diameters have grooved connection.					

Refer to figures on reverse for FPO Nozzle dimensions and for installations details.

#### 5. Approvals:

Class 5136, FM file 3034618



## Integrated Compressed Air Foam Systems

### 6. Nozzle dimensions:

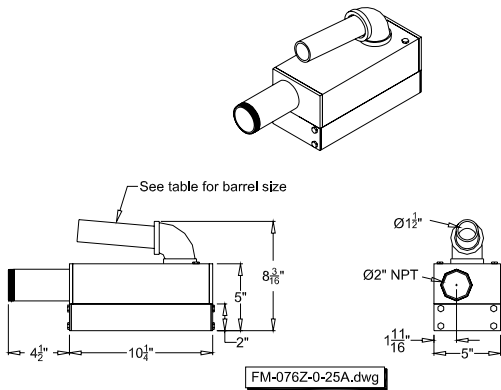

**2" dia. 90° FPO Nozzle with threaded connection**

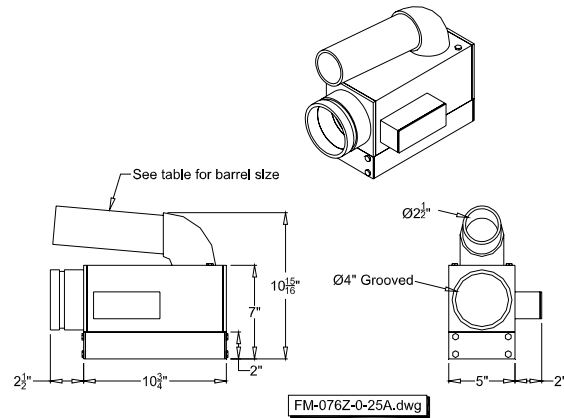

**4" dia. 90° FPO Nozzle with grooved connection**

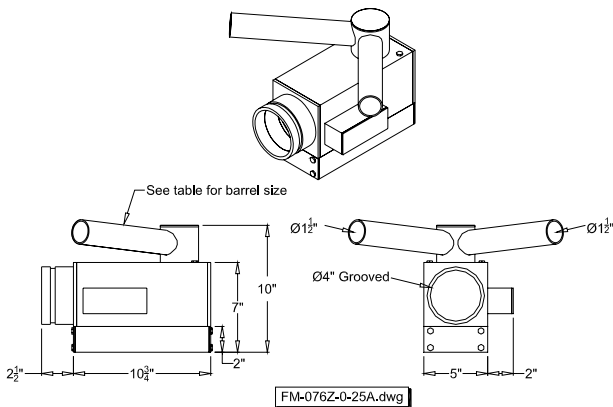

**Typical 180° FPO Nozzle with grooved connection**

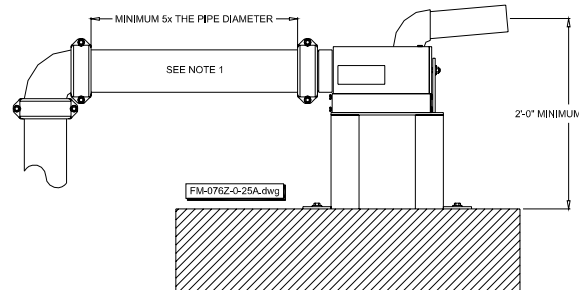

**Typical installation detail**

**Note 1:** For flows of 96 gpm the last straight pipe shall be 3" sch. 10 or sch. 40 pipe.

